

**** NOTES ****

1. HOT DIP GALVANIZED PER ASTM A123 GRADE 75 (LATEST REV)
2. PIPE SHAFT MATERIAL PER ASTM A500 GRADE B MIN YIELD 50 KSI
3. HELIX SHALL BE MADE OF ASTM A572 GRADE 50 OR 80
4. COUPLING BOLTS: 3/4"Ø X 4-1/4" LONG HEX HEAD PER SAE J429 GRADE 8
5. MANUFACTURER TO HAVE IN EFFECT INDUSTRY RECOGNIZED WRITTEN QUALITY CONTROL FOR ALL MATERIALS AND MANUFACTURING PROCESSES
6. ALL WELDING TO BE DONE BY WELDERS CERTIFIED UNDER SECTION 5 OF THE AWS CODE D1.1

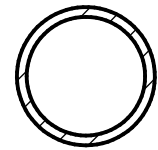

**SECTION A-A
SCALE 1/4**

DESCRIPTION	IMPERIAL	METRIC
SHAFT SIZE, OD	2.875 IN	73.025 mm
SHAFT SIZE, ID	2.469 IN	62.7126 mm
MOMENT OF INERTIA (I)*	1.5295 IN ⁴	6.37x10 ⁵ mm ⁴
SHAFT AREA (A)*	1.70405 IN ²	1099.385 mm ²
SECTION MODULUS (SX-X)*	1.06404 IN ³	17436.5 mm ³
TORQUE	5,500 FT.LBS	7,457 Nm
ULTIMATE CAPACITY	60,000 LBS.	27,215.5 kg
MAX TORQUE VERIFIABLE LOAD	49,500 LBS.	22,452.8 kg

HELICAL PILES

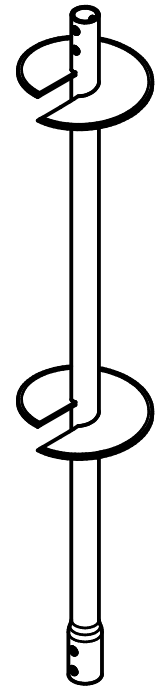
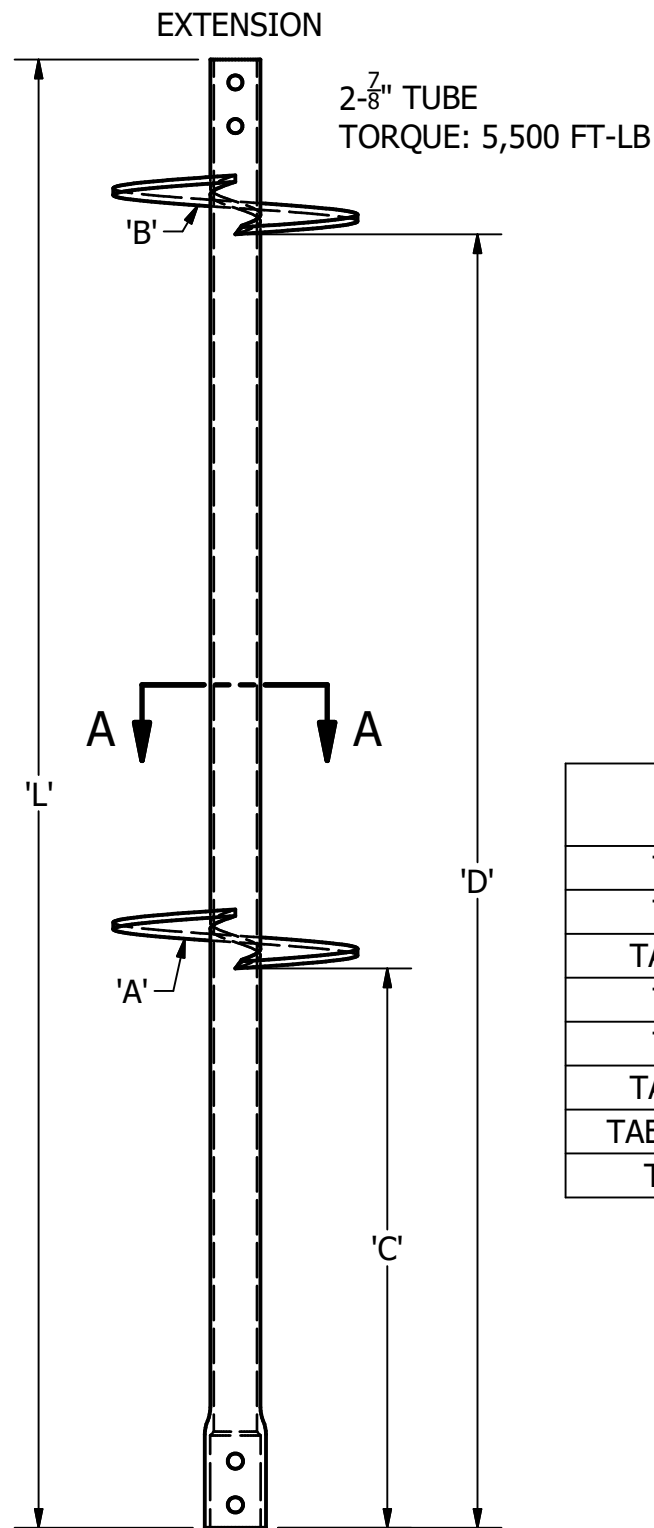

PART NUMBER	DESCRIPTION	'L'	'A'	'B'	'C'	'D'
TAEW-288L-36	36" EXTENSION	36				
TAEW-288L-42	42" EXTENSION	42				
TAEW-288L-42-14	42" EXTENSION W/ 3/8" x 14" HELICAL	42	14		32	
TAEW-288L-60	60" EXTENSION	60				
TAEW-288L-84	84" EXTENSION	84				
TAEW-288L-84-14	84" EXTENSION W/ 3/8" x 14" HELICAL	84	14		32	
TAEW-288L-84-14-14	84" EXTENSION W/ 3/8" x 14"/14" HELICAL	84	14	14	32	74
TAEW-288L-120	120" EXTENSION	120				

ECP	Earth Contact Products			
	TITLE HELICAL PILES TAEW-288L			
CONFIDENTIAL: THIS DRAWING AND ITS CONTENTS ARE CONFIDENTIAL AND THE EXCLUSIVE PROPERTY OF EARTH CONTACT PRODUCTS, LLC. NO PUBLICATION, DISTRIBUTION, OR COPIES MAY BE MADE WITHOUT THE WRITTEN CONSENT OF ECP. ALL RIGHTS RESERVED UNDER THE COPYRIGHT LAWS.	SIZE A	CAT / PART / ASSY NO. SEE CHART	DWG NO. SD-TAE-288L	REV D
DO NOT SCALE THIS DRAWING	DRN BY GDR	DATE 4/11/23	SHEET 1 OF 1	