

** NOTES **

1. HOT DIP GALVANIZED PER ASTM A123 GRADE 75 (LATEST REV)
2. PIPE SHAFT MATERIAL PER A500 GRADE B MIN YIELD 50 KSI
3. HELIX SHALL BE MADE OF ASTM A572 GRADE 50 OR 80
4. COUPLING BOLTS: 3/4"Ø X 4-1/4" LONG HEX HEAD PER SAE J429 GRADE 8
5. MANUFACTURER TO HAVE IN EFFECT INDUSTRY RECOGNIZED WRITTEN QUALITY CONTROL FOR ALL MATERIALS AND MANUFACTURING PROCESSES
6. ALL WELDING TO BE DONE BY WELDERS CERTIFIED UNDER SECTION 5 OF THE AWS CODE D1.1
7. ADD 'H' TO FRONT OF CATALOG NUMBER FOR 1/2" THICK HELICES
8. ICC-ESR-3559

HELICAL PILES

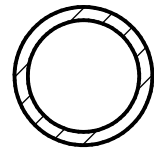
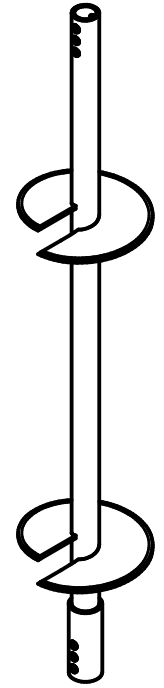
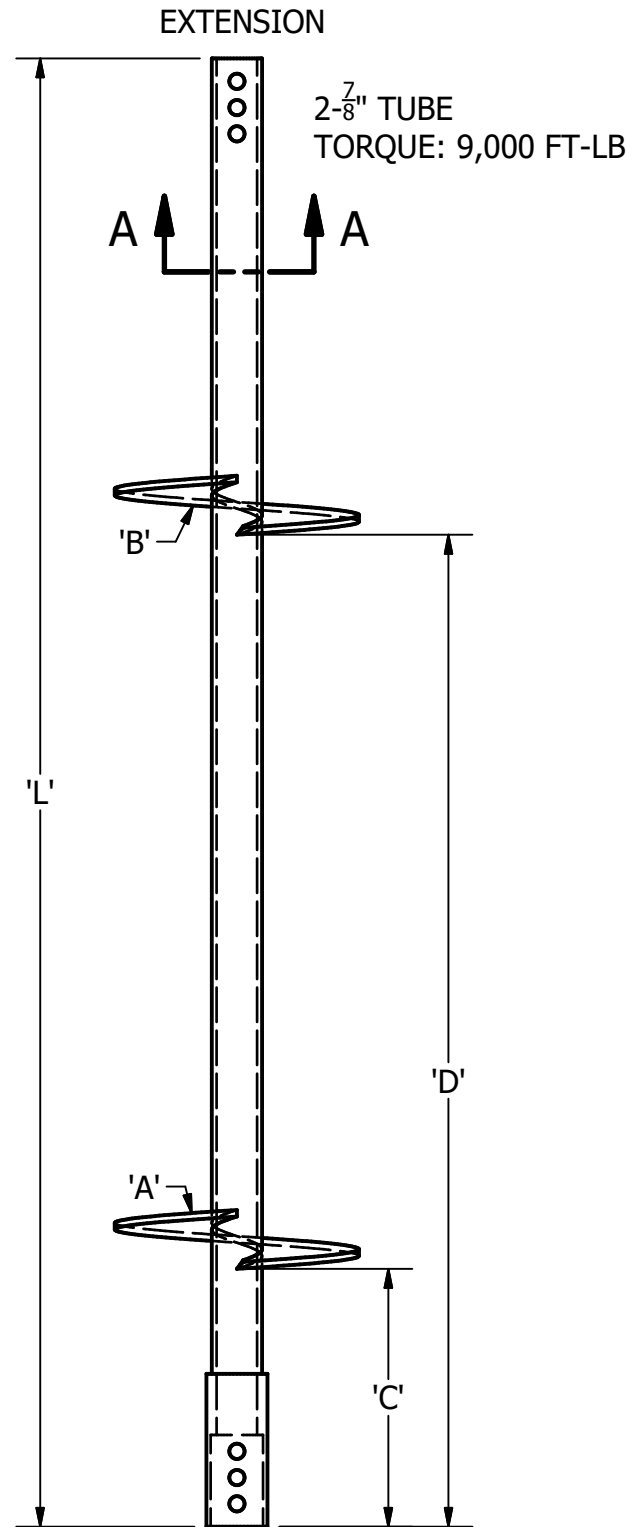

SECTION A-A
SCALE 1/4

DESCRIPTION	IMPERIAL	METRIC
SHAFT SIZE, OD	2.875 IN	73.025 mm
WALL THICKNESS	0.276 IN	7.0104 mm
MOMENT OF INERTIA (I)*	1.9242 IN ⁴	8.01x10 ⁵ mm ⁴
SHAFT AREA (A)*	2.2535 IN ²	1453.87 mm ²
SECTION MODULUS (SX-X)*	1.3386 IN ³	21935.7 mm ³
TORQUE RATING	9,000 FT.LBS	12,202.36 Nm
ULTIMATE CAPACITY	100,000 LBS	45,359.2 kg
MAX TORQUE VERIFIABLE LOAD	81,000 LBS.	36,740.98 kg

PART NUMBER	DESCRIPTION	'L'	'A'	'B'	'C'	'D'
TAEW-288-36	36" EXTENSION	36				
TAEW-288-42	42" EXTENSION	42				
TAEW-288-42-14	42" EXTENSION W/ 3/8" x 14" HELICAL	42	14		15	
TAEW-288-60	60" EXTENSION	60				
TAEW-288-84	84" EXTENSION	84				
TAEW-288-84-14	84" EXTENSION W/ 3/8" x 14" HELICAL	84	14		15	
TAEW-288-84-14-14	84" EXTENSION W/ 3/8" x 14"/14" HELICAL	84	14	14	15	57
TAEW-288-120	120" EXTENSION	120				

	Earth Contact Products			
	TITLE HELICAL PILES TAEW-288			
<small>CONFIDENTIAL: THIS DRAWING AND ITS CONTENTS ARE CONFIDENTIAL AND THE EXCLUSIVE PROPERTY OF EARTH CONTACT PRODUCTS, LLC. NO PUBLICATION, DISTRIBUTION, OR COPIES MAY BE MADE WITHOUT THE WRITTEN CONSENT OF ECP. ALL RIGHTS RESERVED UNDER THE COPYRIGHT LAWS.</small>	SIZE A	CAT / PART / ASSY NO. SEE CHART	DWG NO. SD-TAE-288	REV E
	<small>DO NOT SCALE THIS DRAWING</small>	<small>DRN BY</small> GDR	<small>DATE</small> 4/11/24	<small>SHEET</small> 1 OF 1