

**** NOTES ****

1. HOT DIP GALVANIZED PER ASTM A123 GRADE 100 (LATEST REV)
2. SHAFT MATERIAL HOT ROLLED ROUND CORNER SQUARE SOLID BARS PER ASTM A29; MIN YIELD = 90 KSI
3. HELIX MATERIALS LOW CARBON STEEL MEETING THE GENERAL REQUIREMENTS
4. COUPLING BOLTS: 7/8"Ø X 3-3/4" LONG HEX HEAD PER SAE J429 GR 8
5. MANUFACTURER TO HAVE IN EFFECT INDUSTRY RECOGNIZED WRITTEN QUALITY CONTROL FOR ALL MATERIALS AND MANUFACTURING PROCESSES
6. ALL WELDING TO BE DONE BY WELDERS CERTIFIED UNDER SECTION 5 OF THE AWS CODE D1.1
7. ADD 'H' TO FRONT OF CATALOG NUMBER FOR 1/2" THICK HELICES
8. ICC-ESR-3559

HELICAL PILES

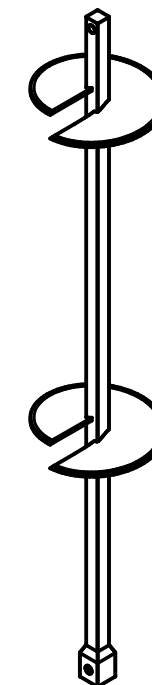
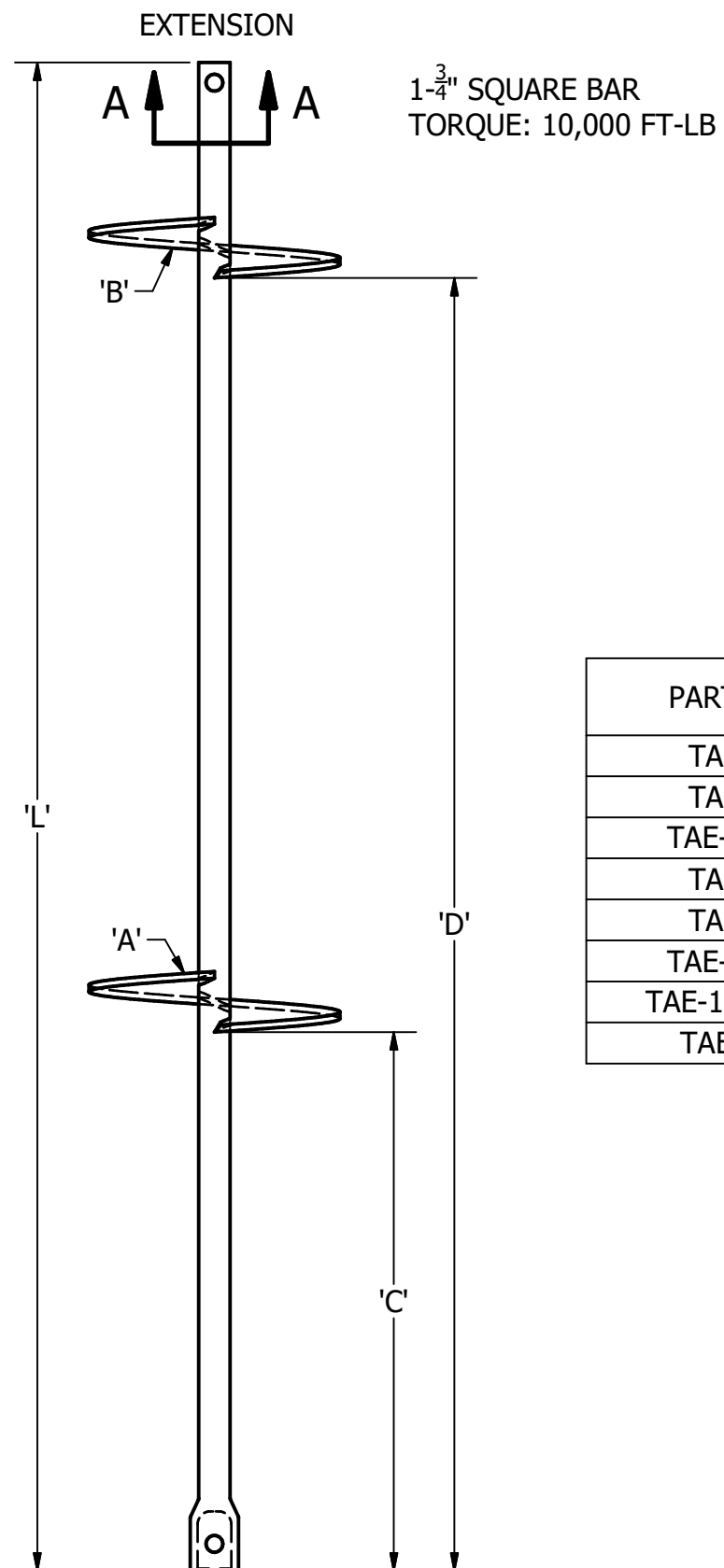

SECTION A-A
SCALE 1/4

PART NUMBER	DESCRIPTION	'L'	'A'	'B'	'C'	'D'
TAE-175-36	36" EXTENSION	36				
TAE-175-42	42" EXTENSION	42				
TAE-175-42-14	42" EXTENSION W/ 3/8" x 14" HELICAL	42	14		11.5	
TAE-175-60	60" EXTENSION	60				
TAE-175-84	84" EXTENSION	84				
TAE-175-84-14	84" EXTENSION W/ 3/8" x 14" HELICAL	84	14		29	
TAE-175-84-14-14	84" EXTENSION W/ 3/8" x 14"/14" HELICAL	84	14	14	29	72
TAE-175-120	120" EXTENSION	120				

DESCRIPTION	IMPERIAL	METRIC
SHAFT SIZE	1.75 IN	44.45 mm
MOMENT OF INERTIA (I)*	0.7816 IN ⁴	3.253x10 ⁵ mm ⁴
SHAFT AREA (A)*	3.0125 IN ²	1943.5445 mm ²
SECTION MODULUS (SX-X)*	0.89323 IN ³	14637.4172 mm ³
TORQUE	10,000 FT.LBS	13558 Nm
ULTIMATE CAPACITY	100,000 LBS.	45360 kg

ECP	Earth Contact Products			
	TITLE HELICAL PILES TAE-175			
CONFIDENTIAL: THIS DRAWING AND ITS CONTENTS ARE CONFIDENTIAL AND THE EXCLUSIVE PROPERTY OF EARTH CONTACT PRODUCTS, LLC. NO PUBLICATION, DISTRIBUTION, OR COPIES MAY BE MADE WITHOUT THE WRITTEN CONSENT OF ECP. ALL RIGHTS RESERVED UNDER THE COPYRIGHT LAWS.	SIZE A	CAT / PART / ASSY NO. SEE CHART	DWG NO. SD-TAE-175	REV C
DO NOT SCALE THIS DRAWING	DRN BY GDR	DATE 4/11/23	SHEET 1 OF 1	