

** NOTES **

1. HOT DIP GALVANIZED PER ASTM A123 GR 100 (LATEST REV)
2. SHAFT MATERIAL HOT ROLLED ROUND CORNER SQUARE SOLID BARS PER ASTM A29; MIN YIELD 90 KSI
3. HELIX SHALL BE MADE OF ASTM A572 GRADE 50 OR 80
4. COUPLING BOLTS: 3/4"Ø X 3" LONG HEX HEAD PER SAE J429
5. MANUFACTURER TO HAVE IN EFFECT INDUSTRY RECOGNIZED WRITTEN QUALITY CONTROL FOR ALL MATERIALS AND MANUFACTURING PROCESSES
6. ALL WELDING TO BE DONE BY WELDERS CERTIFIED UNDER SECTION 5 OF THE AWS CODE D1.1
7. ADD 'H' TO FRONT OF CATALOG NUMBER FOR 1/2" THICK HELICES
8. ICC-ESR-3559

HELICAL PILES

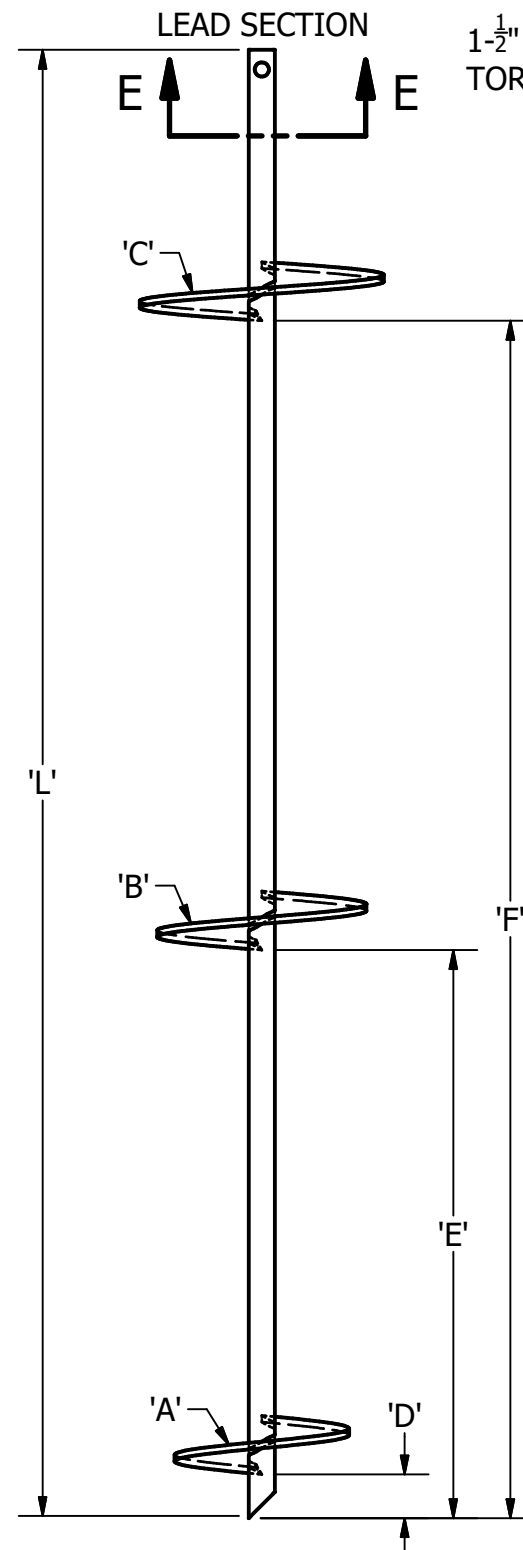

1-1/2" SQUARE BAR
TORQUE: 7,000 FT-LB



SECTION E-E
SCALE 1/4

DESCRIPTION	IMPERIAL	METRIC
SHAFT SIZE	1.5 IN	38.1 mm
MOMENT OF INERTIA (I)*	0.421875 IN	1.76x10 ⁵ mm
SHAFT AREA (A)*	2.2 IN	1419.35 mm
SECTION MODULUS (SX-X)*	0.5625 IN	9217.7235 mm
TORQUE	7,000 FT.LBS	9490 Nm
ULTIMATE CAPACITY	70,000 LBS.	31750 kg

PART NUMBER	DESCRIPTION	'L'	'A'	'B'	'C'	'D'	'E'	'F'
TAH-150-10-8	10" LEAD W/ 3/8" x 8" HELICAL	10	8			2.5		
TAH-150-10-10	10" LEAD W/ 3/8" x 10" HELICAL	10	10			2.5		
TAH-150-10-12	10" LEAD W/ 3/8" x 12" HELICAL	10	12			2.5		
TAH-150-10-14	10" LEAD W/ 3/8" x 14" HELICAL	10	14			2.5		
TAH-150-60-8	60" LEAD W/ 3/8" x 8" HELICAL	60	8			2.5		
TAH-150-60-10	60" LEAD W/ 3/8" x 10" HELICAL	60	10			2.5		
TAH-150-60-12	60" LEAD W/ 3/8" x 12" HELICAL	60	12			2.5		
TAH-150-60-14	60" LEAD W/ 3/8" x 14" HELICAL	60	14			2.5		
TAF-150-60-8-10	60" LEAD W/ 3/8" x 8" / 10" HELICALS	60	8	10		2.5	26.5	
TAF-150-60-10-12	60" LEAD W/ 3/8" x 10" / 12" HELICALS	60	10	12		2.5	32.5	
TAF-150-60-12-14	60" LEAD W/ 3/8" x 12" / 14" HELICALS	60	12	14		2.5	38.5	
TAH-150-84-8	84" LEAD W/ 3/8" x 8" HELICAL	84	8			2.5		
TAH-150-84-10	84" LEAD W/ 3/8" x 10" HELICAL	84	10			2.5		
TAH-150-84-12	84" LEAD W/ 3/8" x 12" HELICAL	84	12			2.5		
TAH-150-84-14	84" LEAD W/ 3/8" x 14" HELICAL	84	14			2.5		
TAF-150-84-8-10	84" LEAD W/ 3/8" x 8" / 10" HELICALS	84	8	10		2.5	26.5	
TAF-150-84-10-12	84" LEAD W/ 3/8" x 10" / 12" HELICALS	84	10	12		2.5	32.5	
TAF-150-84-12-14	84" LEAD W/ 3/8" x 12" / 14" HELICALS	84	12	14		2.5	38.5	
TAF-150-84-8-10-12	84" LEAD W/ 3/8" x 8"/10"/12" HELICALS	84	8	10	12	2.5	26.5	56.5
TAF-150-84-10-12-14	84" LEAD W/ 3/8" x 10"/12"/14" HELICALS	84	10	12	14	2.5	32.5	68.5
TAH-150-120-8	120" LEAD W/ 3/8" x 8" HELICAL	120	8			2.5		
TAH-150-120-10	120" LEAD W/ 3/8" x 10" HELICAL	120	10			2.5		
TAH-150-120-12	120" LEAD W/ 3/8" x 12" HELICAL	120	12			2.5		
TAH-150-120-14	120" LEAD W/ 3/8" x 14" HELICAL	120	14			2.5		
TAF-150-120-8-10	120" LEAD W/ 3/8" x 8" / 10" HELICALS	120	8	10		2.5	26.5	
TAF-150-120-10-12	120" LEAD W/ 3/8" x 10" / 12" HELICALS	120	10	12		2.5	32.5	
TAF-150-120-12-14	120" LEAD W/ 3/8" x 12" / 14" HELICALS	120	12	14		2.5	26.5	
TAF-150-120-8-10-12	120" LEAD W/ 3/8" x 8"/10"/12" HELICALS	120	8	10	12	2.5	26.5	56.5
TAF-150-120-10-12-14	120" LEAD W/ 3/8" x 10"/12"/14" HELICALS	120	10	12	14	2.5	32.5	68.5



Earth Contact Products

CONFIDENTIAL: THIS DRAWING AND ITS CONTENTS ARE CONFIDENTIAL AND THE EXCLUSIVE PROPERTY OF EARTH CONTACT PRODUCTS, LLC. NO PUBLICATION, DISTRIBUTION, OR COPIES MAY BE MADE WITHOUT THE WRITTEN CONSENT OF ECP. ALL RIGHTS RESERVED UNDER THE COPYRIGHT LAWS.

TITLE HELICAL PILES TAH-150 / TAF-150			
SIZE A	CAT / PART / ASSY NO. SEE CHART	DWG NO. SD-TA-150	REV B
DO NOT SCALE THIS DRAWING	DRN BY GDR	DATE 8/2/23	SHEET 1 OF 1