

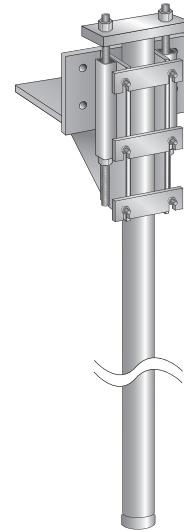

## The ECP Steel Pier

The Patented ECP Model 350 steel pier is the original ECP Steel Pier. Since its inception the Model 350 pier has set the standard for the foundation repair industry. The patented design supports structures by penetrating deeply in the soil giving structures a new, deep foundation. Earth Contact Products, the leaders in steel pier technologies, is known for the strongest and deepest driving pier systems available for commercial and residential use.



### *Designed and Engineered to Perform!*

The ECP Model 350 Steel Pier uses a two-stage system of driving steel pilings to a verified bearing stratum, then using our unique manifold system you can now recover lost elevation of the structure. Even on the heaviest of structures the Model 350 pier system can close cracks in masonry and restore elevations lost due to settlement. The ECP Model 350 was designed to provide the strongest support for your foundation.

Quiet, vibration free equipment is used to install all ECP steel piers. The equipment is portable for easy access in hard to reach areas such as basements and low overhead access areas. Installation is all below ground and is then covered, so upon completion, there will be no visible signs that a repair was performed. If you need your home or office structurally repaired due to settlement, the ECP Model 350 will give your foundation a lifetime of support.

### **Designed to be the strongest foundation structural support in the industry**

- Made of galvanized steel pier material
- Individual and verifiable capacities
- The industry standard in support
- Installs with portable hydraulic equipment
- Designed by engineers

The Engineer's Choice in Quality  
Structural Repair Underpinning.

**EARTH  
CONTACT  
PRODUCTS**

**1-866-327-0007**

15612 S Keeler Terr.

Olathe, Ks 66062

Phone: 913-393-0007

Fax: 913-393-0008

info@getecp.com

www.getecp.com

**ECP**



## ECP Steel Pier™ - Model 350 Pier System

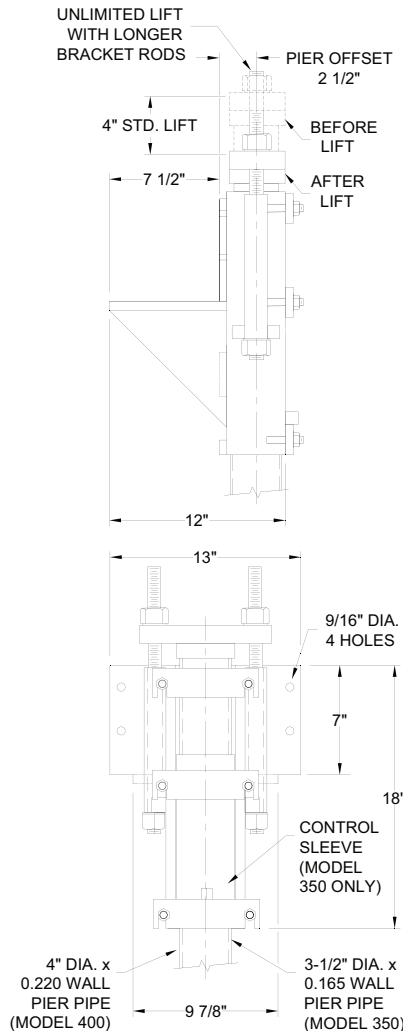

**Model 350 & Model 400 Utility Bracket Details**

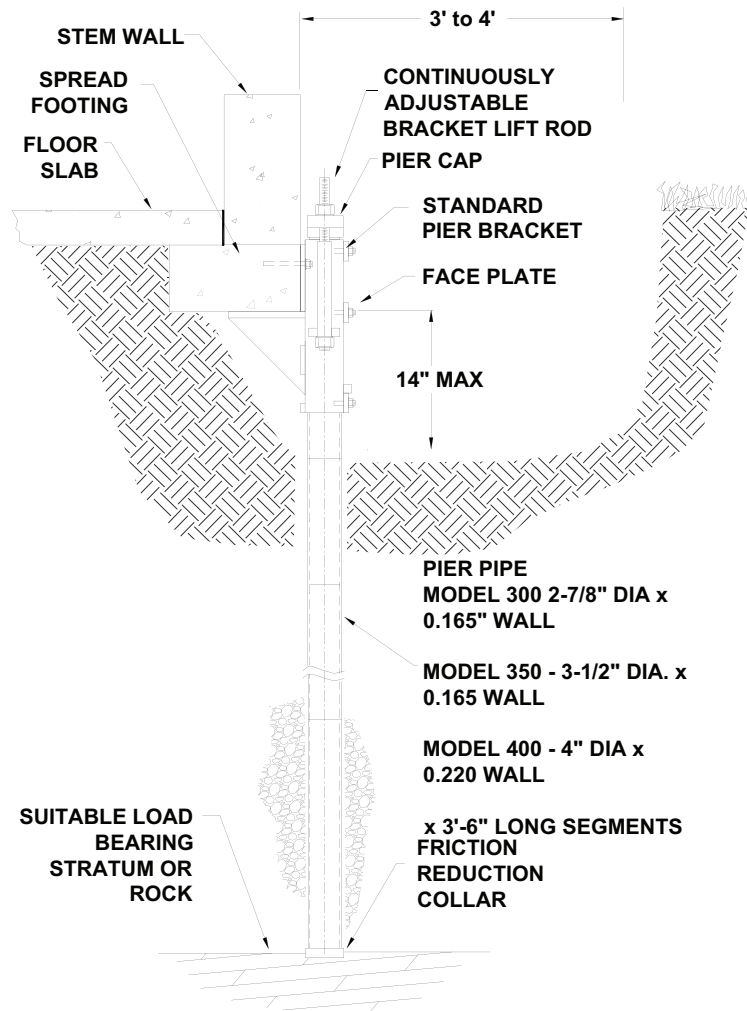

**Model 350 & Model 400 Utility Bracket Application Drawing**

- Ultimate Capacity – 99,000 lb
- Fully Adjustable Unlimited Lift Capability
- Installs From Outside or Inside Structure
- 3-1/2" Diameter High Strength, Galvanized Tubular Pier
- Installed With Little or No Vibration
- Installs To Rock or Verified Load Bearing Stratum
- 100% of Piers Field Load Tested During Installation

### EARTH CONTACT PRODUCTS

**1-866-327-0007**

15612 S Keeler Terr.  
 Olathe, Ks 66062  
 Phone: 913-393-0007  
 Fax: 913-393-0008  
 info@getecp.com  
 www.getecp.com

